

USER MANUAL

IW-H20LC

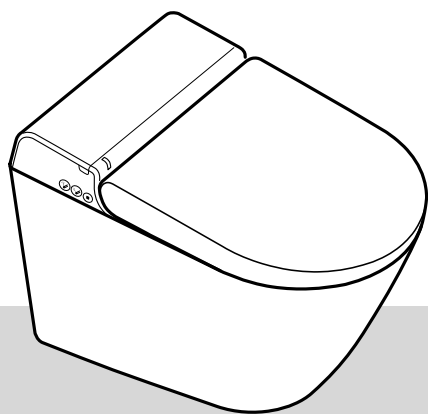

HYGEA

Table of Contents

Preparation

1. Identification _____ 1
2. Safety information _____ 2

How to Use

3. Preliminary information _____ 8
4. How to Use _____ 9
5. Water quality test and settings _____ 13
6. Automatic descaling program _____ 14
7. Preliminary checks before requesting service — 16
8. How to prepare the unit for service _____ 17

Important Information

9. Specifications _____ 23
10. Warranty _____ 24

- Please carefully read this instruction manual for proper use of this appliance.
- The product warranty is included in this instruction manual.
- Please contact our company for any inquiries during use.
- After the box is opened and the appliance is installed, no return or exchange is allowed.
- ※ This appliance is for AC 230 V only so please make sure to check before installing.

1. Identification

Main unit

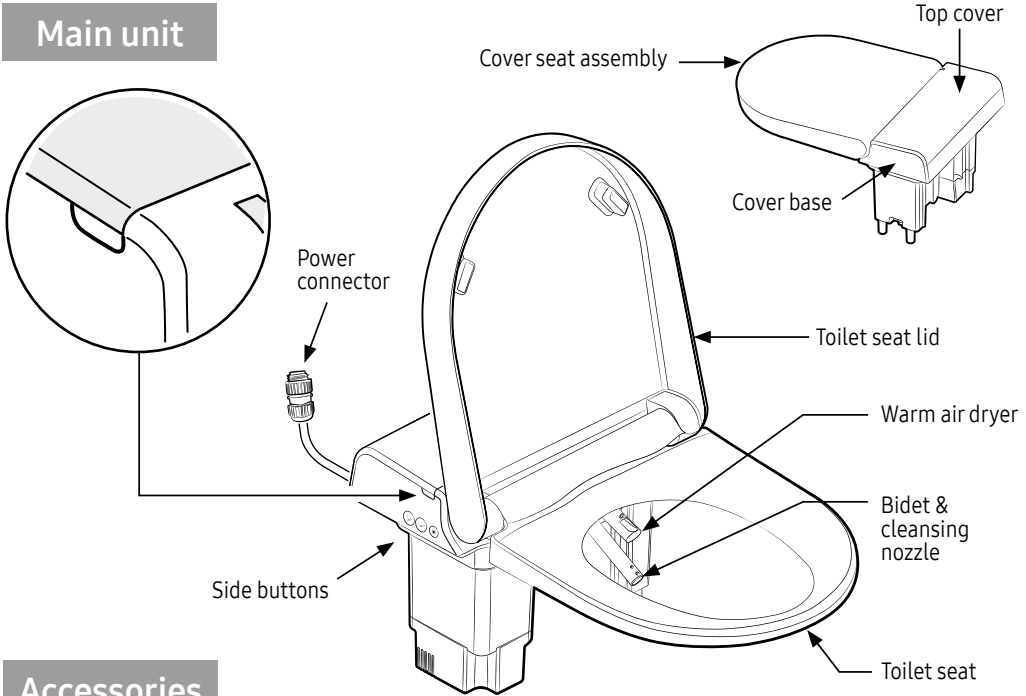

Accessories

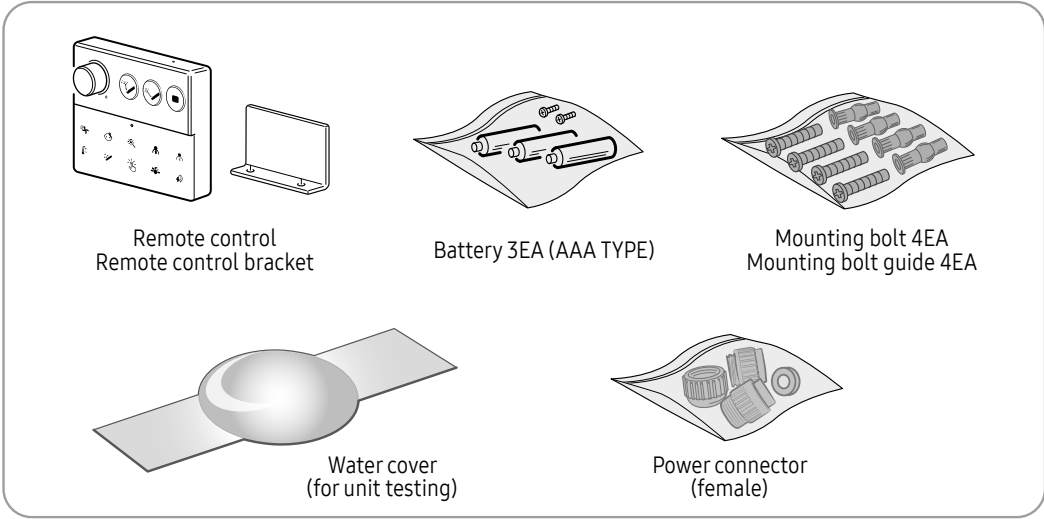

※ Specifications and details may change for enhancement of performances.

2. Safety Information

Follow these basic instructions to ensure the proper use of the appliance and prevent any danger or physical damage in advance.

READ ALL INSTRUCTIONS BEFORE USING

DANGER - To reduce the risk of electric shock:

1. Do not place or store this appliance where it can fall or be pulled into a tub or sink.
2. Do not place in, or drop into water or other liquid.
3. Do not reach for a product that has fallen into water. Unplug immediately.

WARNING - To reduce the risk of burns, electric shock, fire or injury to people:

1. Close supervision is necessary when this appliance is used by or near children, elderly or invalid. Children should not be permitted to use or touch this appliance without the supervision of an adult.
2. Use this appliance only for its intended purpose as described in this manual. Do not use attachments not recommended by the manufacturer.
3. Never operate this appliance if it has a damaged cord or plug, if it is not working properly, if it has been dropped, damaged or dropped into water.
4. Install this appliance properly according to this manual.
5. Only authorized people can install or repair this appliance. Do not attempt to repair this appliance by yourself, doing so could void the warranty.
6. Keep the cord away from heated surfaces.
7. Never drop or insert any object into any opening or hose.
8. Do not use outdoors. Do not use aerosol or oxygen spray products on the unit.
9. Always follow the grounding instruction in this manual before plugging in.
10. If the supply cord is damaged, it must be replaced by the manufacturer, its service agent or similarly qualified people in order to avoid a hazard.
11. This appliance can be used by children aged from 3 years and above and persons with reduced physical, sensory or mental capabilities or lack of experience and knowledge if they have been given supervision or instruction concerning use of the appliance in a safe way and understand the hazards involved.
12. Children shall not play with this appliance.
13. Cleaning and user maintenance shall not be made by children without supervision.

SAVE THESE INSTRUCTIONS

NOTE THE FOLLOWING IMPORTANT POINTS

1. Do not install in location where water might be splashed on this appliance or in location exposed to such an excessive moisture that condensation forms on the product surface.
2. To avoid damage to electronic components due to high levels of humidity, provide adequate ventilation by opening a window and/or door when bathing. You may find operating an exhaust ventilating fan during these times of high humidity beneficial.
3. The new hose-set supplied with the appliance should be used and the old hose-set should not be reused.
4. Use a water supply having a water pressure 0.05 MPa ~ 1.00 MPa.
5. Connect the product to a pipe carrying potable water. Do not connect to an industrial water line or other water supply that does not carry water of drinking quality.
6. In areas where water freezes during winter make arrangements to keep the pipes warm. The water remaining in the unit may sometimes freeze during storage in winter. In that case, warm the unit in the room before installation.
7. The thermal protector in the water tank may sometimes trip during storage or transportation in warm weather causing non-operation. In that case, cool the unit in the room before installation.
8. The rated power voltage is 220-240 V~ 50/60 Hz.
9. Do not supply electrical power to the unit until the plumbing installation work has been completed; it could cause malfunction.
10. Turn off the appliance during maintenance and cleaning.
11. Use only the original Hygea - Durgol® descaling liquid tested and approved for this product. Not doing so may cause malfunctions to the product, corrosion to the internal components, and potential risks for the user.

RECYCLING



This marking shown on the product or its literature indicates that it should not be disposed of with other household waste at the end of its working life. To prevent possible harm to the environment or human health from uncontrolled waste disposal, please separate this from other types of wastes and recycle it responsibly to promote the sustainable reuse of material resources.

Household users should contact either the retailer where they purchased this product or their local government office, for details of where and how they can take this item for environmentally safe recycling.

Business users should contact their supplier and check the terms and conditions of the purchase contract.









This product should not be mixed with other commercial waste for disposal.

2. Safety Information

ENG
DEU
FR
ITA
ESP

Warnings

Follow these basic instructions to ensure the safe use of your appliance.

-  Indicates a prohibited use of the appliance.
 -  Indicates a required step in use of this appliance.
-
-  Prohibited
 -  Do not handle with wet hands
 -  Use of fire prohibited
 -  Do not disassemble
 -  Do not spray water
 -  Required step
 -  Ground connection



Meanings of symbols

Prohibited
Stop using a damaged power cord or a loose electrical outlet and call the service center immediately.

- Doing so may result in an electric shock, short circuit or fire.



Do not spray water
Do not splash water or detergent on the product or cord and do not use it in a place with too much humidity.

- If not followed it may result in a fire or electric shock.



Do not handle with wet hands
Do not plug or unplug with wet hands and make sure not to grab the cord when unplugging.

- Unplugging the cord with wet hands may result in an electric shock or injury.
- Once dust, etc. piles up on the cord or outlet, wipe and clean it with a dry cloth as it may result in an electric shock or fire due to moisture.



Use of fire prohibited
Do not throw a lit cigarette or anything flammable into the toilet or bathroom.

- If not followed it may result in a fire.



Ground connection
For outlets to plug the appliance, use only those that are grounded.

- If not followed it may result in a malfunction or electric shock.
- If the outlet is not grounded, make sure to use only after grounding it by requesting to a designated electrical work operator.
- When purchasing a new outlet, make sure to purchase a grounded outlet.

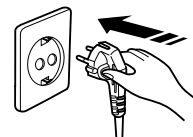

Warnings

Follow these basic instructions to ensure the safe use of your appliance.



Prohibited

Do not use the appliance on a power strip.

- If not followed it may result in fire or damage.
- If a foreign substance or moisture is on the power cord, make sure to wipe it well before using the appliance.

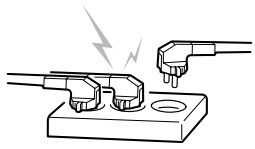

Do not disassemble

Do not disassemble, repair or modify this appliance.

- If not followed it may result in a fire, electric shock or injury.

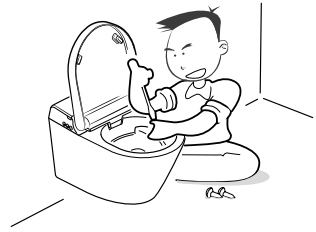

Required step

Turn off the power switch when it beeps or emits a strange odour.

- Turn off the power switch right away.
- Request the customer service center for repair.



- This appliance can be used by children aged from 8 years and above and persons with reduced physical, sensory or mental capabilities or lack of experience and knowledge if they have been given supervision or instruction concerning use of the appliance in a safe way and understand the hazards involved.
- Children shall not play with the appliance.
- Cleaning and user maintenance shall not be made by children without supervision.

2. Safety Information

ENG
DEU
FR
ITA
ESP

Caution

Follow these basic instructions to ensure the safe use of your appliance.

!
Required step

Turn off the power switch when cleaning or if you do not plan to use it for a long time due to a trip, etc.



!
Required step

Turn off the power switch while there is thunder or lightning.

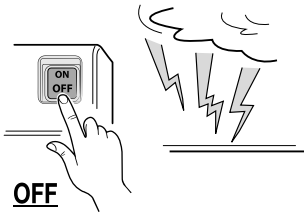

!
Required step

Use this appliance on a toilet only, so do not use it for any other purposes.

If not followed it may cause a fire, electric shock, or injury (damage).

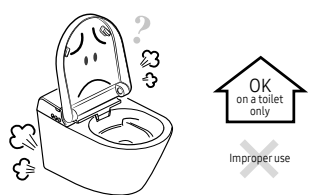

⊘
Caution

Do not pull out the water hose forcefully from the connection.

If not followed it may cause water leakage.



!
Required step

Do not splash any polluted substances such as urine on the bidet.

If not followed it may cause an odour or malfunction.



!
Required step

Do not forcefully close the toilet seat or the lid.

If not followed it may result in a malfunction.
 Be cautious not to let your fingers be jammed when opening or closing the toilet seat or the lid.



Caution

Follow these basic instructions to ensure the safe use of your appliance.



Caution

Do not lean on the toilet seat lid.

- ❑ If not followed it may result in malfunction or damage.

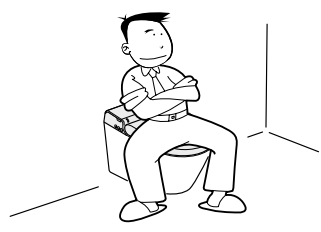

Caution

Do not put a vase, cup, container of cosmetics, chemicals or water, or small metals on the appliance.

- ❑ If it goes inside, it may cause a fire or electric shock.

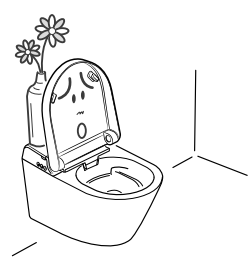

Required step

Use the lowest temperature setting for children and people with disabilities.

- ❑ If a high temperature is set up, it may result in potential burns.

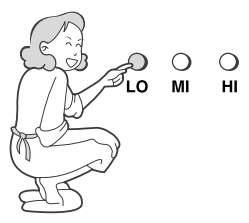

CAUTION

Risk of fire or explosion if the batteries of the remote control are replaced by an incorrect type.

3. Preliminary information

1. Technical details

Specifications		
Rating	AC 220-240 V, 50/60 Hz	
Flow rate for cleansing	Level 5	1,000cc/min(±200)
	Level 1	750 cc/min(±200)
Flow rate for bidet	Level 5	1,000cc/min(±200)
	Level 1	750 cc/min(±200)
Water heater electrical consumption	800 W	
Solenoid valve	DC 12 V	
Dryer	Temp. levels	5 levels
	Power	SOFT
TURBO		135 W(±15%)

2. Remote control specifications

[Top View]

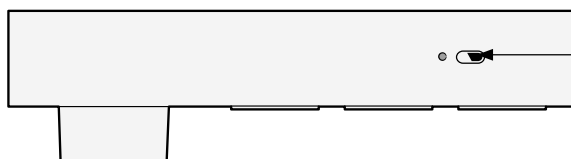

Low battery level

[Main View]

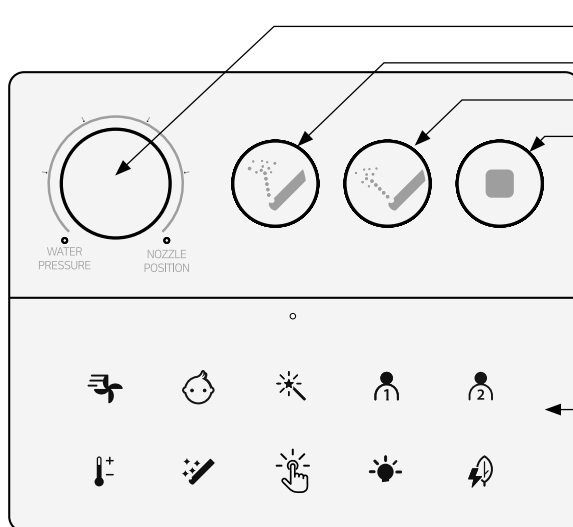

Operational Knob

Cleansing

Bidet

Stop

Touch panel*

* Touch  to activate the touch panel.

4. How to use

※ The unit radar sensor will activate when the user is within a ray of 50-60 cm from the product.

1. Batteries insertion

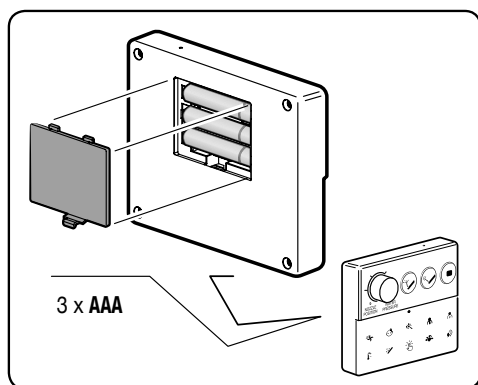

2. Manual pairing

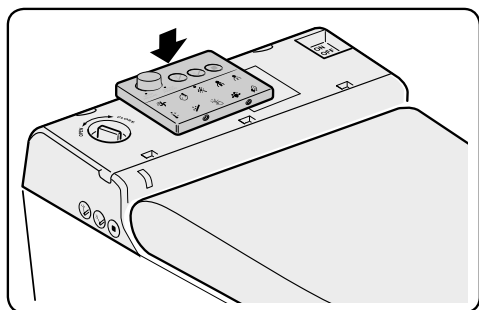

- Remove the TOP COVER.
- Turn the main unit OFF.
- Push the knob on the remote control for 5 sec. – it will activate manual pairing mode. (30 sec.)
- When the pairing mode is turned ON, LED (Blue) on the remote control blinks 3 times.
- Put the remote control on the COVER BASE.
- Turn the main unit ON.
- When pairing is complete, the unit LED (Blue) blinks 3 times and the unit also beeps 3 times.

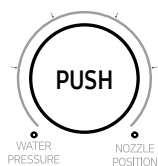

3. Functions

1) Cleansing (Rear)



- Touch the Cleansing function. (When Radar Sensor is ON)
- For oscillating mode, touch Cleansing again.
- Press the knob during operation to set water pressure. Press again to set nozzle position. Water pressure and nozzle position can be set up to five levels.
- The device remembers the previous user's water pressure / nozzle position.
- Duration: 40 sec.
- When operating with side buttons, push the relative button.
- Side buttons default:
Water Pressure: Level 3
Nozzle: Level 3.

2) Bidet (Front)



- Touch the Bidet function. (When Radar Sensor is ON)
- For oscillating mode, touch Bidet again.
- Press the knob during operation to set water pressure. Press again to set nozzle position. Water pressure and nozzle position can be set up to five levels.
- The device remembers the previous user's water pressure / nozzle position.
- Duration: 40 sec.
- When operating with side buttons, push the relative button.
- Side buttons default:
Water Pressure: Level 3
Nozzle: Level 3.

3) Stop



- Touch the Stop function to end all operations.
- When operating with side buttons, push the relative button.

4. How to use

4) Dry



- Touch the Dry function. (When Radar Sensor is ON)
- For turbo mode touch Dry function during dry.
- Duration: 180 sec.
- Turn the knob to select the temperature.



5) Kids



- Touch the Kids function. (When Radar Sensor is ON)
- Cleansing + Oscillating mode for 40 sec. (Pressure Level 1, Nozzle Position Level 5) → Dry for 180 sec. (Temp. Level 3)
- In 220 sec. operation will be completed or touch the Stop function.
- It reverts to previous user's water pressure / nozzle position and dry temperature.

6) Auto Nozzle Cleaning



- Touch the function in Stop mode to operate. (Violet LED on)
- Duration: 30 sec.
- Cleansing / Bidet / Auto / Kids / Dry function cannot be operated during Auto Nozzle Cleaning.
- In any moment touch the Stop function first to reactivate the other functions.

7) Manual Nozzle Cleaning



- Touch the function for 5 sec. in Stop mode to operate. (Violet LED blinks)
- Duration: 180 sec.
- Cleansing / Bidet / Auto / Kids / Dry function cannot be operated during Manual Nozzle Cleaning.
- In any moment touch the Stop function first to reactivate the other functions.

8) Energy Saving



- Touch  to see current Energy Saving level on LED.
- Touch Energy Saving function: 3 Levels. (Eco, Super Eco, Normal)
- Eco: LED (Yellow) / Water temp. 30°
- Super Eco: LED (Green) / Water temp. OFF
- Normal: LED (White)
- When Eco and Super Eco are activated, the unit will reduce the energy consumption during stand-by mode. (Radar Sensor OFF)
- When Radar Sensor is ON, the unit will restore previous settings.

9) Auto



- Touch the Auto function (When Radar Sensor is ON)
- Cleansing for 20 sec. → Cleansing + Oscillating mode 20 sec. (Water pressure: Level 2) → Dry 180 sec. (Dry temp.: Level 3).
- In 220 sec. operation will be completed or touch the Stop function.
- The unit reverts to previous user's water pressure / nozzle position and dry temperature.
- Default mode: Cleansing Auto function.
- During Cleansing, touch Auto function → Auto function ON. (Cleansing)
- During Bidet, touch Auto function → Auto function ON (Bidet).

10) Water Temperature

- Touch  to see current temperature on LED.
- Touch the Water Temperature function to change temperature level.
- Low, Middle, High, OFF (4 Level)
- Factory default, OFF (White)
- Water temp. 33° "Low" (Green)
- Water temp. 36° "Mid" (Yellow)
- Water temp. 39° "High" (Red)

11) Water Pressure / Dry Temperature

- Default: Water pressure control. (Water pressure led is on).
- During Dry, adjust the temperature of air.
- Turn the knob to select the desired water pressure / dry temperature.

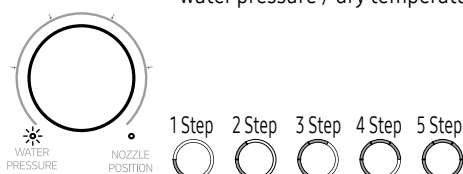

12) Nozzle Position

- Default: Water pressure control. (Water pressure LED is on) → Push to adjust for the nozzle position. (Nozzle position LED is on).
- Turn the knob to select the desired nozzle position.



13) User's Profiles

- A. User set up
- Step 1: Touch User1 (User2).
User Setting time (30 sec.).
 - Step 2: Touch Cleansing or Bidet function.
 - Step 3: Set water pressure / nozzle position by adjusting it (refer to sections 11 and 12).
 - Step 4: Touch User1 (User2) to save setting.
- B. How to use
- Step 1: Touch Cleansing or Bidet function.
 - Step 2: Touch User1 (User2) to operate as setting.

14) Low Battery Level

- When batteries are low, the LED icon on the top of the remote control blinks. (Look at page 8)

15) Anti-lime stone

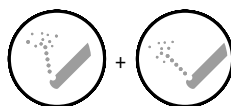

- When the visual alarm turns on (Red and Blue LED flickers), touch the Cleansing + Bidet function for 5 sec. (Remote or on the side buttons)
- Duration: about 65 min, Alarm will beep when anti-lime stone function is completed. Refer to the Automatic Descaling Program section at page 14.
- If power is turned off or blackout happen during anti-lime stone mode, when power is back on Anti-lime stone function will reactivate automatically for 5 times.

4. How to use

16) Water Draining

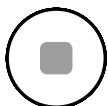

- Touch the Stop function for 5 sec. (Remote or side buttons) to start the automatic draining function.
- Use this function and turn OFF the unit if you do not plan to use it for a long time.
- Touch the Stop function briefly to stop water draining and return to the water filling operation.
- Duration: About 120 sec. (Blue LED on)

17) Sound

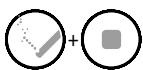

- Press Stop + Bidet function on the side buttons to activate / deactivate sound.

18) Function lock



- Default mode: OFF.
- Press the Cleansing function (on the side buttons) for 5 seconds to activate/deactivate the lock of all the functions.
- Mode OFF -> ON
 - 1) A short beep signals that the operation has been completed
 - 2) LED turns RED.
- Mode ON -> OFF
 - 1) A long beep signals that the operation has been completed
 - 2) LED goes back to the previous color.

19) Night Light LED



- Touch the Light function to activate / deactivate Night Light LED.
- A delicate light under the bowl will guide the user to identify the unit during the night.
- When the Light function is OFF, the LED under the bowl will flash 3 times when the radar sensor detects the user.

- Factory Default: ON.
- Light ON mode.
 - 1) Radar Sensor ON: Color (As setting) / Brightness (Level 1)
 - 2) Radar Sensor OFF: Color (As setting) / Brightness (As setting)
- Light OFF mode.
 - 1) Radar Sensor ON: Violet LED under the bowl blinks 3 times and turns off.

20) Night Light LED color/brightness



How to set the Light. (Default: Blue)

Step 1: Touch the Light function for 5 sec. to activate Light selection mode. (Light function blinks)

Step 2: Turn the knob to select the color.

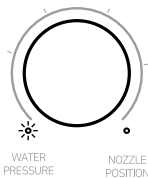

1:Blue 2:SkyBlue 3:Green 4:Violet 5:Red



- Push the knob to set the brightness. (Default: Level 5)



Level 1 Level 2 Level 3 Level 4 Level 5



Step 3: To complete setting, touch the Light function.

- If the setting is not complete in 30 sec. or other functions are pressed previous settings will be maintained.
- During Light mode setting, pushing the knob will change from color to brightness mode and viceversa.

5. Water quality test and settings

1. Fill a glass with fresh and cold water from the tap.

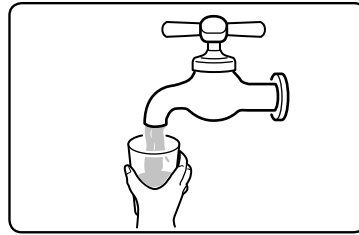

2. Place a litmus paper for 1 second inside the water contained in the glass cup and wait 60 seconds.



3. Check the test results according to the table.

<p>Kurz eintauchen (1 s), leicht abschütteln und nach 1 min ablesen.</p> <p>5 grün/green/vert 1 rot/red/rouge 2 rot/red/rouge 3 rot/red/rouge 4 rot/red/rouge 5 rot/red/rouge</p>	<p>Dip briefly (1 s), shake off excess water and compare after 1 min.</p>	<p>Plongez brièvement (1 s), égouttez l'excès d'eau et comparez après 1 min.</p> <p>0° dH/ 0.00° e/ 0° f 5° dH/ 6.25° e/ 9° f 10° dH/ 12.50° e/ 18° f 15° dH/ 18.75° e/ 27° f 20° dH/ 25.00° e/ 36° f 25° dH/ 31.25° e/ 45° f</p>	<p>AQUADUR®</p> <ul style="list-style-type: none"> • Teststäbchen zur Bestimmung der Wasserhärte • Test strip for determination of water hardness • Bandelette pour déterminer la dureté de l'eau
---	---	---	---

4. Set the limestone removal period depending on the test results.

How to set the alarm cycle setting to activate the Automatic descaling program. (Factory Default: Hardness III)

Step 1: Touch the Cleansing + Stop function for 5 sec. to activate Anti-limestone alarm. (Pressure / Nozzle LED blinks)

Step 2: Turn the knob to select the alarm cycle.

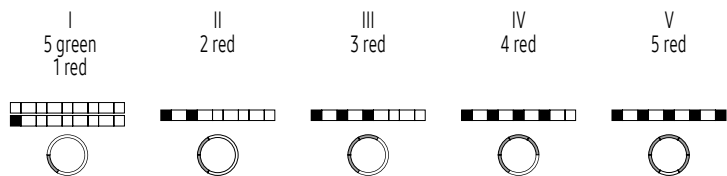
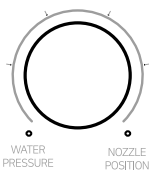
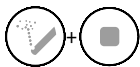

Step 3: To complete setting, touch the Stop function.

- If the setting is not complete in 30 sec. or other functions are pressed, the factory default setting will be maintained.

6. Automatic descaling program

1. Alarm.

- Red and Blue LED flickers.

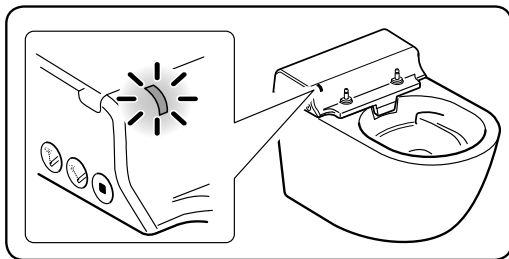

2. Preparation.

- Lift the front of the TOP COVER first and open it by lifting it up.

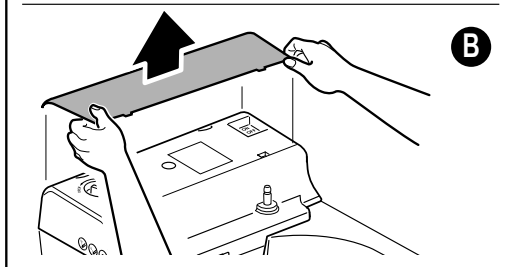
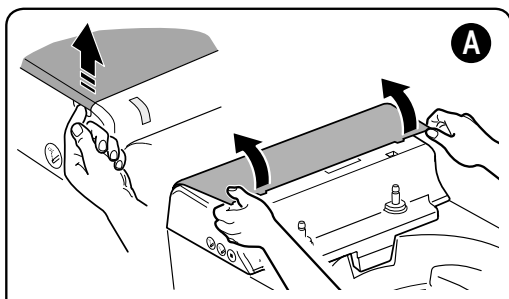

- Turn the Limestone cover to the left to open it.

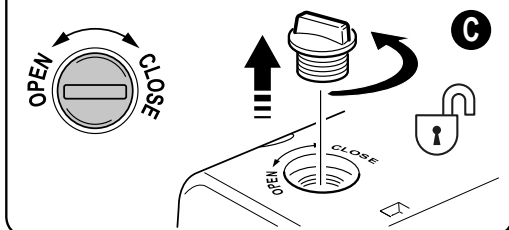

3. Press the Cleansing + Bidet button for 5 seconds.

- Blue LED displays.
- Blue LED blinks in 5 sec.

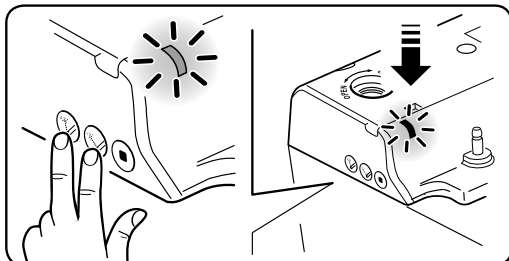

4. Blue LED blinks.
- Insert the descaling liquid.

* Use only the original Hygea - Durgol® descaling liquid provided in the accessory box or purchased from your local distributor. The use of a descaling liquid different from the original one may cause malfunctions to the product.

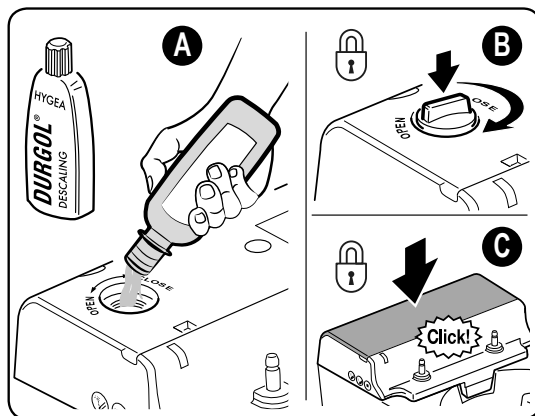

5. Press the Bidet button.
- Purple LED turns on.

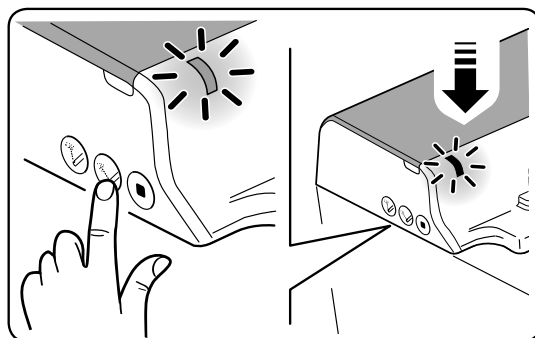

6. White LED turns on.
- Limestone removal and cleansing in progress.
- Operates for approx 60 minutes.

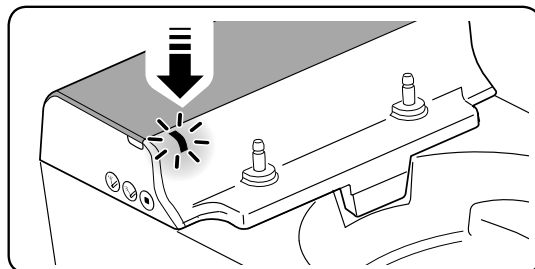

7. Purple LED turns on.
- Additional cleansing proceeded.
- Operates for 10-11 minutes.

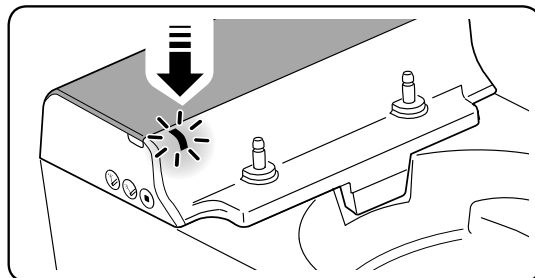

8. Returns to the initial settings.

7. Preliminary checks before requesting service

Symptoms	How to inspect	Solutions
It does not work at all.	<ul style="list-style-type: none">• Isn't there a blackout or an unplugged power cord?• Isn't the power turned off?	<ul style="list-style-type: none">- Insert the cord properly.- Turn on the power switch.
The water does not come out.	<ul style="list-style-type: none">• Isn't the water stop valve or water supply valve closed?• Is the nozzle clogged?	<ul style="list-style-type: none">- Open the water supply valve.- Clean the nozzle.
The water leaks outside.	<ul style="list-style-type: none">• Check if the water hose connection part is well tightened.	<ul style="list-style-type: none">- If it continues to leak, contact the customer center.
The water is not warm.	<ul style="list-style-type: none">• Isn't the hot water temperature set to OFF?• Isn't the Super Eco Mode on while the surrounding temperature is low?	<ul style="list-style-type: none">- Repeat the temperature setting.- Deactivate the Super Eco Mode.
The LED on the main unit flickers.	<ul style="list-style-type: none">• Hasn't the power cord become loose?	<ul style="list-style-type: none">- Unplug the power cord and then insert it again properly.- If it continues to flicker, contact the customer center.

8. How to prepare the unit for service

Procedure

1. Touch the Stop function for 5 sec. (Remote or side buttons).
 - The automatic water draining time is about 2 minutes.

* Alternatively, it is possible to manually drain the unit by opening the drain bolt under the tank (refer to point 6.1 after following points 2 to 6).

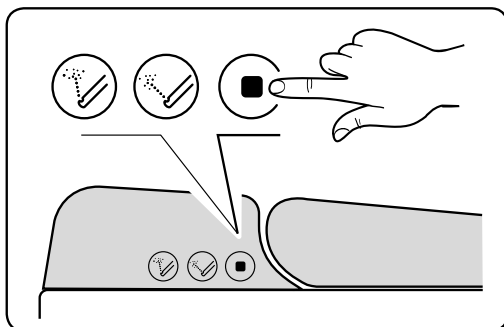

2. Lift the COVER SEAT ASSEMBLY to disassemble it.

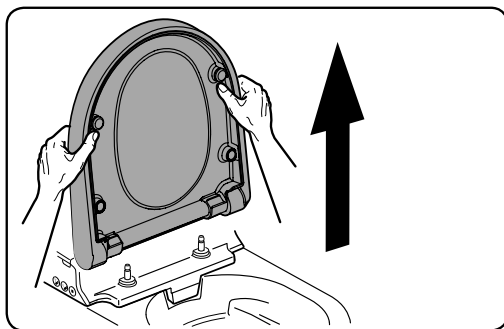

3. Lift the front of the TOP COVER first and disassemble it by lifting it up.

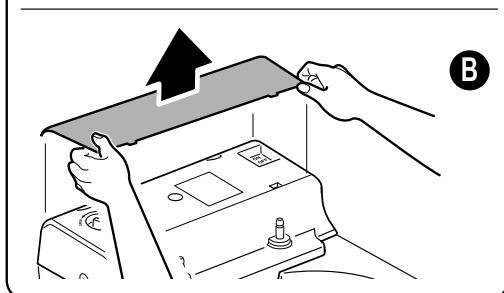
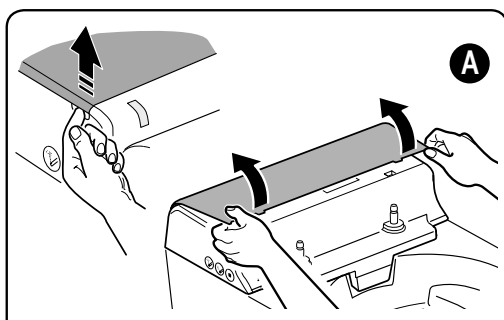

8. How to prepare the unit for service

4. Turn "OFF" the power switch.

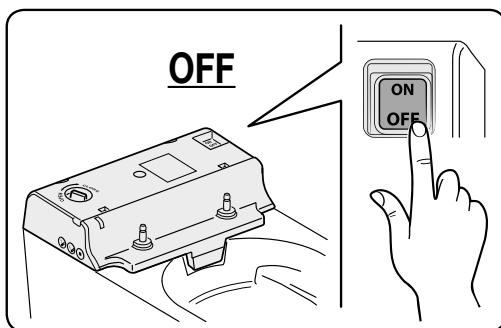

5. Use a (+) screwdriver to remove 2 COVER BASE SCREWS.
Separate the COVER BASE.

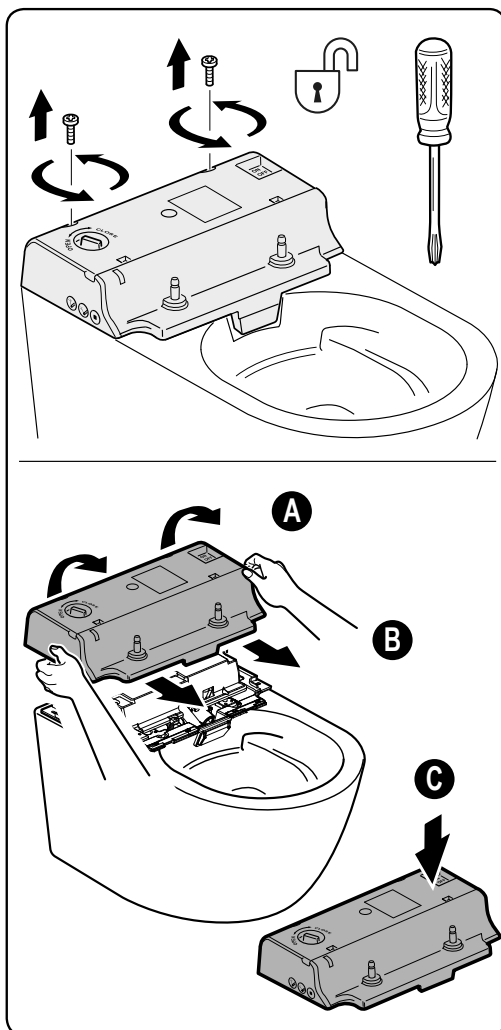

6. Push 2 hooks to the inside to lift up the bidet. Be careful as the water hose and the power connector are connected.

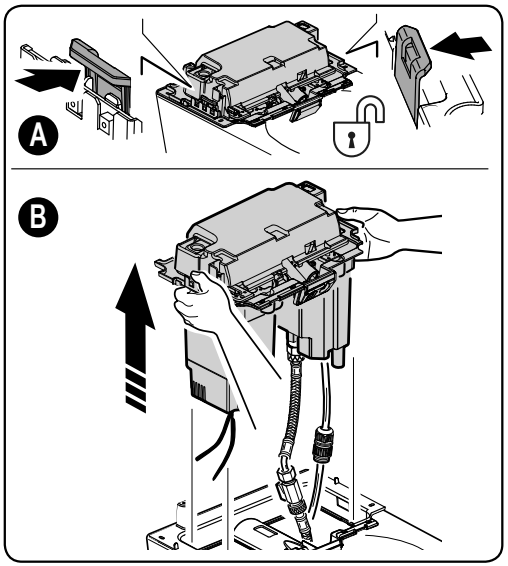

6.1. If automatic draining is not possible, unscrew the drain bolt under the tank. Otherwise, you can ignore this step.

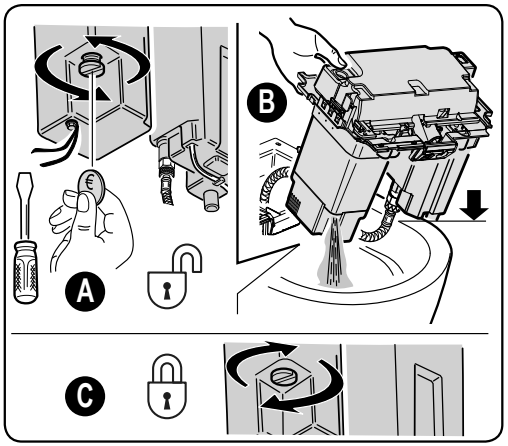

7. Close the stop valve of the water hose.

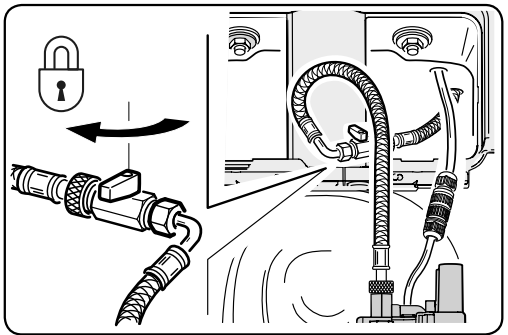

8. How to prepare the unit for service

8. Separate the water hose and the power connector.

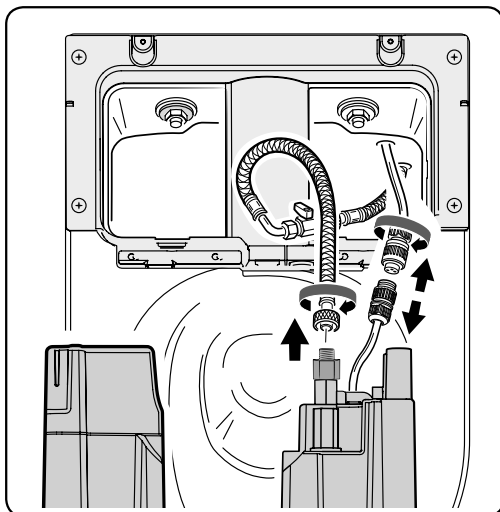

9. Fix the COVER BASE into the 2 grooves on the front first and push down the back to assemble it.
Assemble the 2 SCREWS.

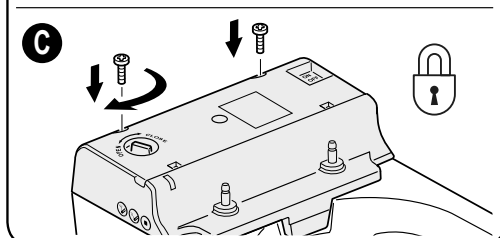
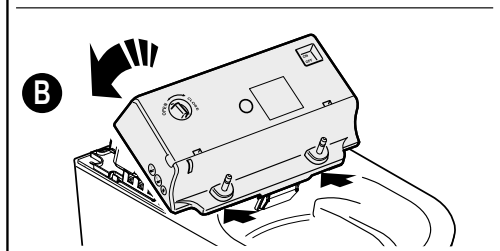
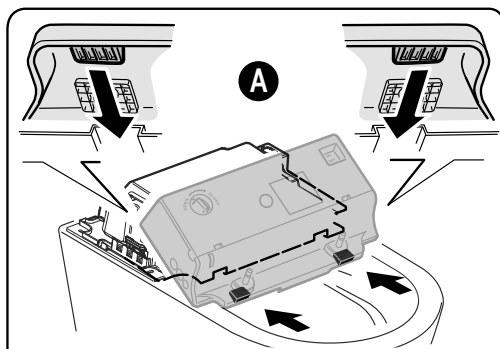

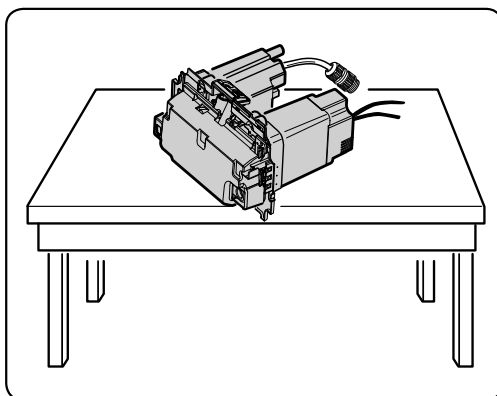

10. Fix the front of the TOP COVER first and push down the back to assemble it.

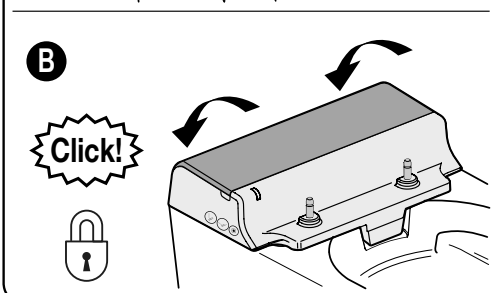
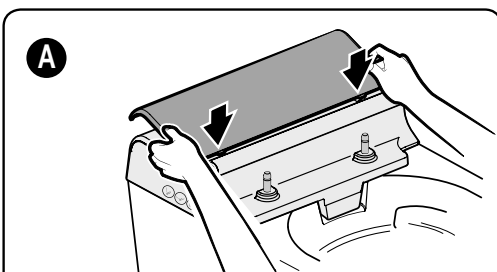

11. Insert the COVER SEAT ASSEMBLY on the pins to assemble it.

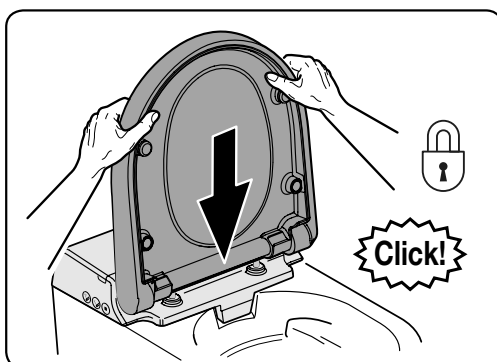

8. How to prepare the unit for service

12. Put the disassembled bidet into a box to pack it.
Pack it and request for a service.

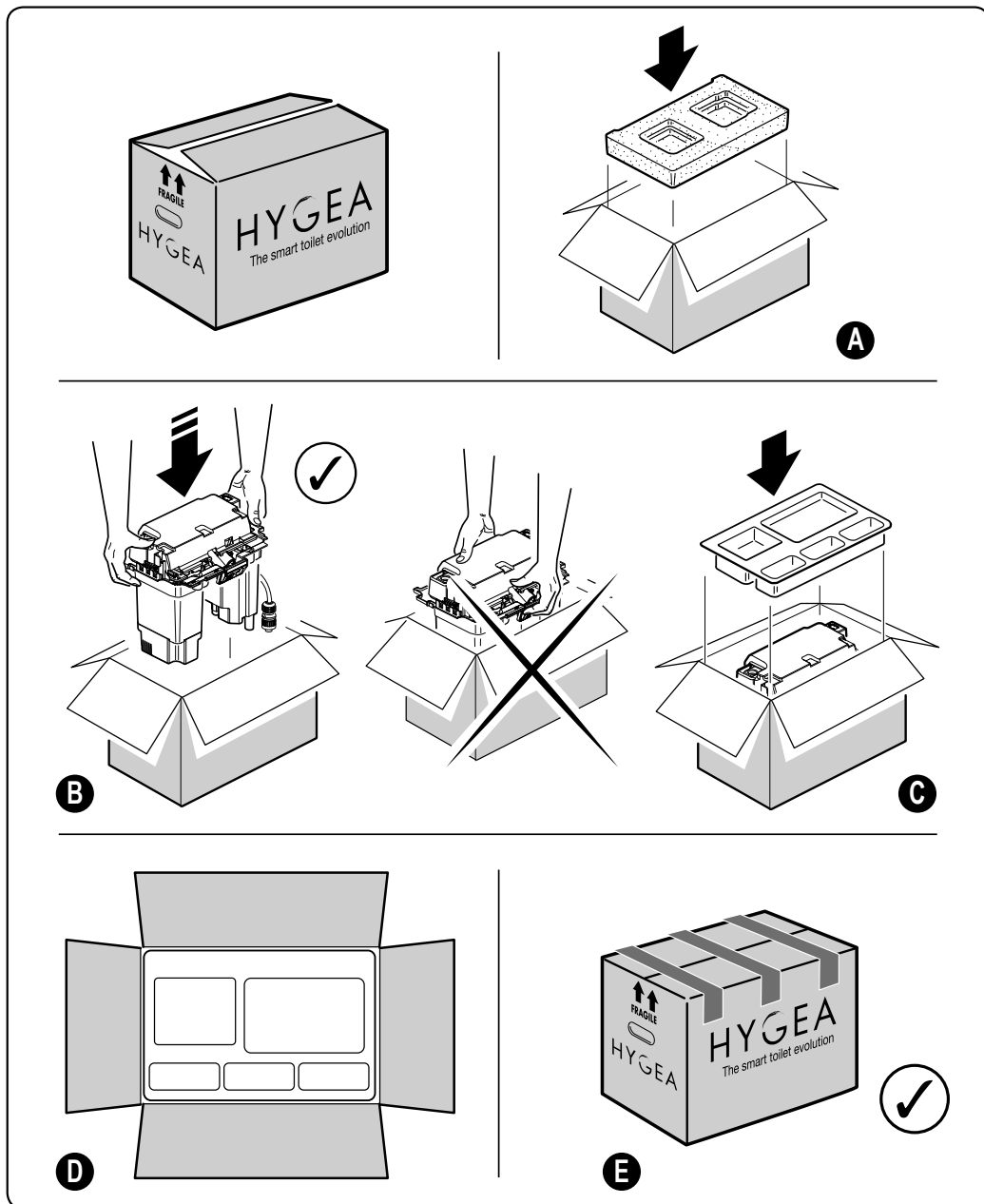

9. Specifications

No	Specifications		
1	Rating	Rated voltage	AC 220 - 240 V
		Rated frequency	50 / 60 Hz
2	Water supply	Water supply method	Direct-coupled water supply system
		Pressure	0.5 ~ 10 bar / 0.05 - 1.00 MPa
3	Tank	Capacity	1,000 ~ 1,200 CC
		Type of thermostat	53 °C non auto return type
		Heater capacity	800 W
		Water temperature	OFF, 33 °C, 36 °C, 39 °C
4	Cleansing device	Amount sprayed	1,000 cc / min ± 200 cc
		Move	Select
		Nozzle position control	5 Levels
		Water pressure control	5 Levels
		Cleaning	Auto and Manual cleaning
5	Blower	Drying fan	DC 12 V Max
		Warm-air drying	MOTOR-BLOWER
		Power consumed	135 W ± 15%
		Safety System	Bimetal (auto return)
6	Remote Control Rating	Operating Voltage	DC 2.5 ~ 4.5 V
		Operating Current (TA=25 °C, 3.0 V)	35 mA (Operation Current ≤ 35 mA)
7	Product size		(W)381 mm x (D)225 mm x (H)306 mm
8	Maximum seat and cover seat load		150 Kg
9	Product weight		3.6 Kg
10	Package weight		5.5 Kg
11	Maximum ambient temperature		45 °C

※ The recommended water pressure is from 0.5 to 10 bar / 0.05 to 1.00 MPa.

10. Warranty

USPA Personal Hygiene Appliance Limited Warranty

- We warrant our products to be free from manufacturing defects under normal use and service for a period of two (2) years from date of your purchase. Only the ORIGINAL PURCHASER may make a claim under this limited warranty.
- Our obligation to you under this warranty is limited to repair or replacement, at our option, of defective products or parts, provided that the products were properly installed and used in accordance with instructions. We reserve the right to make inspections in order to determine the cause of the defect. We will not charge for labor or parts in connection with warranty repairs or replacement. We are not responsible for the cost of removal, return and/or reinstallation of products.
- This limited warranty does not apply to:
 - a) Damage or loss from fire, earthquake, flood, storm, etc.
 - b) Damage or loss resulting from any unreasonable use, abuse, negligence or improper maintenance.
 - c) Damage or loss from improper installation, removal, repair, or modification.
 - d) Damage or loss resulting from sediment or other matters contained in your water system.
- Only the original purchaser may submit a claim under this limited warranty.
- This limited warranty is our only warranty covering your product. Repair or replacement as provided under this warranty shall be the exclusive remedy available to you. We shall not be responsible for loss of the product or for other incidental, or consequential damage or expenses you may incur or for labor or other costs due to installation or removal or cost or repairs by others, or for any other expense not specifically stated above. Except to the extent prohibited by applicable law, any implied warranties, including that of merchantability or fitness for use are expressly limited to the duration of this warranty.
- * Warning! We are not responsible or liable for any failure of or damage to this plumbing product component caused by in-tank bowl cleaners containing chlorine (calcium hypochlorite).
- * Note: the use of high concentration of chlorine related products can seriously damage the product and the fittings. This damage can cause leakage and serious property damage.

For more information, please contact your dealer or us.

GSI S.p.A.

Sp 150 Km 3,125

01035 GALLESE (VT) – ITALY

TEL: +39 0761 4911

www.gsiceramica.it

info@gsiceramica.it

Notes

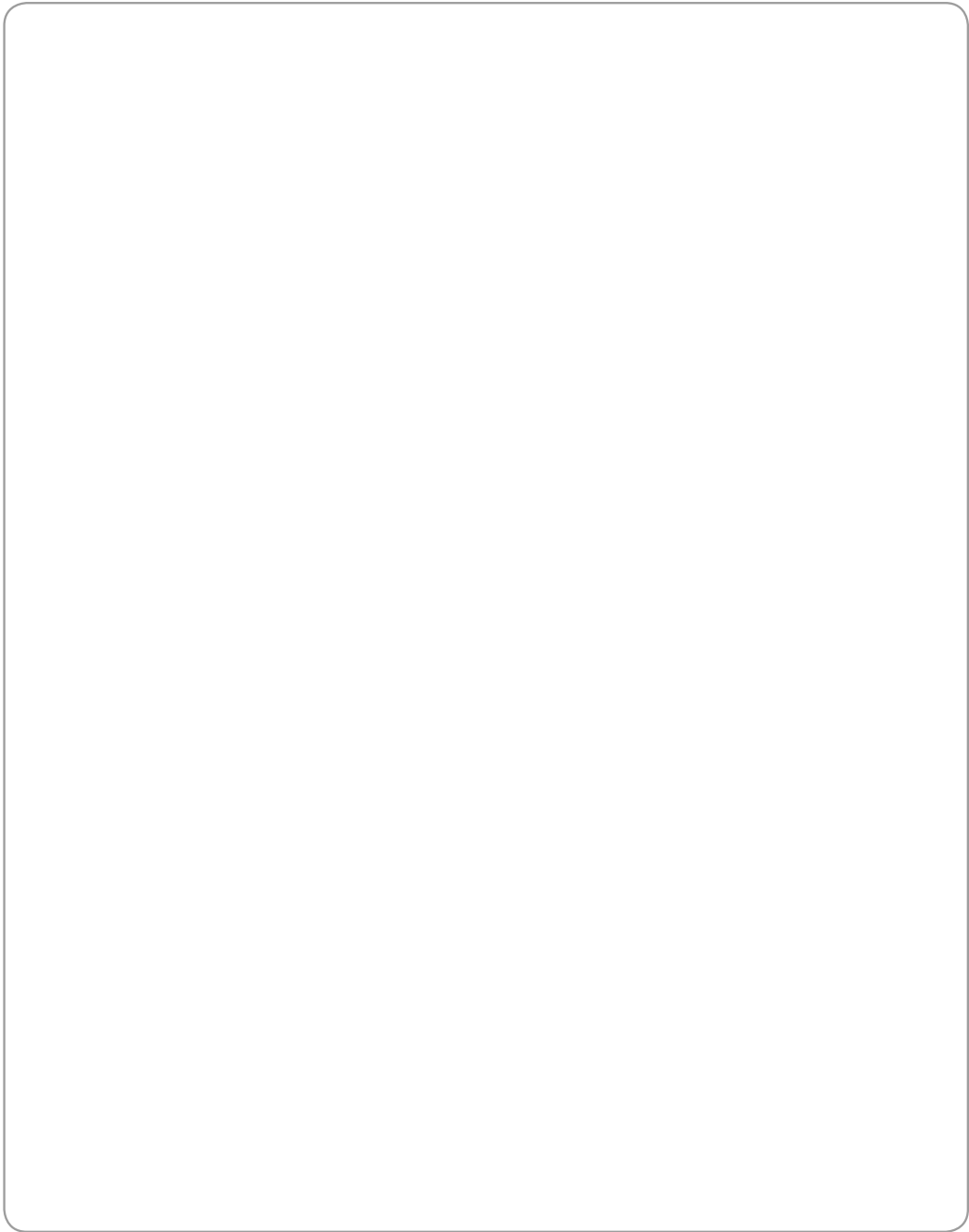
A large, empty rectangular box with rounded corners, intended for taking notes. The box is white and occupies most of the page below the header.

USPA EUROPE S.r.l.
Corso della Vittoria, 14 - 28100 NOVARA - Italy
☎ +39 0321 030449 - www.uspa.eu - info@uspa.eu